

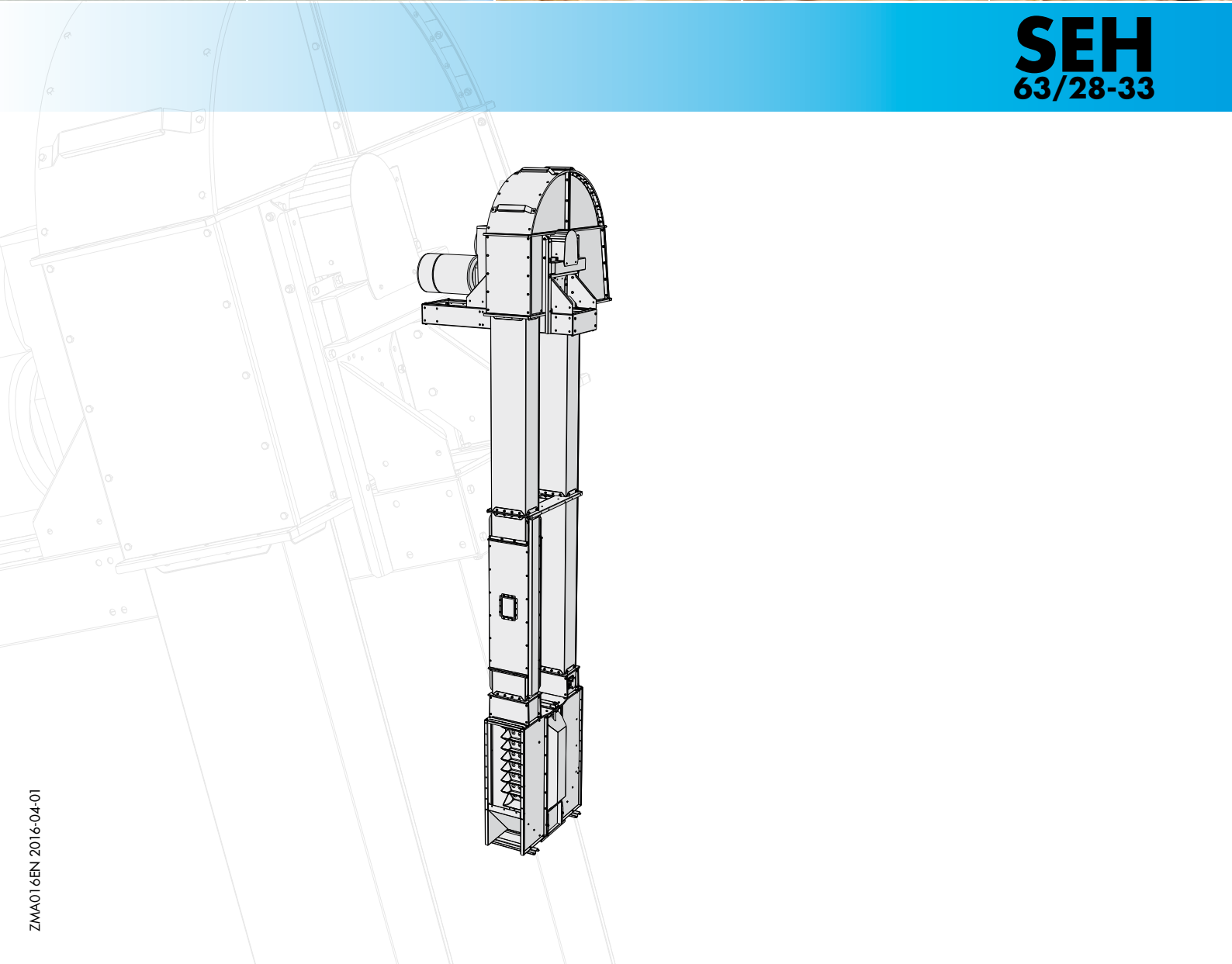

**SEH**  
63/28-33





## Goods inspection

Check that the number of packages agrees with the delivery note and that the packing and goods are not damaged. Make a note of any damage and missing materials on the consignment note and report it to the carrier and to us. Make sure the delivery is complete after unpacking the goods. Any materials that are found to be incorrect must not be assembled.

## Warranty

A 2-year factory warranty from the day of delivery applies to all models of Skandia Elevator AB machinery. A condition of the warranty and any subsequent compensation is that Skandia Elevator AB is contacted and an agreement reached between the customer and Skandia Elevator AB on how any faults should be rectified. The warranty covers all parts that are damaged or break due to faulty design or manufacture. Faults and damage caused by faulty assembly, incorrect use or lack of maintenance will not be covered by the warranty.

## CE mark

A CE mark is located on the transmission side of the elevator head and is proof that the machine has been manufactured in accordance with EU machine directives and complies with safety requirements. The CE mark contains information concerning year of manufacture, model designation and order number. Always specify the order number in the event of a claim and on orders for spare parts.

## EC Declaration

Skandia Elevator AB  
Arentorp  
S-53494 Vara  
SWEDEN

declare under our sole responsibility that the product:

## SEH

order number:

.....  
to which this declaration relates is in conformity with Council Directive of 29 December 2009 on the harmonisation of the member States relating to machinery, 2006/42/EC.

Unless otherwise specified on the CE mark, the product is manufactured in accordance with EU Machinery Directive and is classified as Category II 2D/OD. It is intended for the transport of materials that correspond with ATEX Zone 21 and the external environment is unclassified.

Vara 29/12 2009

Joakim Larsson, CEO



## Thank you for choosing Skandia Elevator!

Your conveyor system must be assembled correctly and maintained thoroughly if it is to operate satisfactorily. These assembly instructions and the separate maintenance instructions must be followed for the warranty to apply.

We hope you will be pleased with your Skandia conveyor equipment for a long time.

|  |           |
|--|-----------|
| <b>Machine overview</b> .....                    | <b>6</b>  |
| <b>Safety information</b> .....                  | <b>7</b>  |
| General safety information .....                 | 7         |
| Electrical safety .....                          | 8         |
| Safety decals .....                              | 9         |
| <b>Before assembly</b> .....                     | <b>11</b> |
| <b>Connection of the machine</b> .....           | <b>13</b> |
| Location of inlet .....                          | 13        |
| Connecting another machine to the elevator ..... | 13        |
| Connecting the elevator to the conveyor .....    | 13        |
| <b>Assembling the machine</b> .....              | <b>14</b> |
| Elevator legs .....                              | 14        |
| Elevator head .....                              | 15        |
| Back stop .....                                  | 16        |
| Bucket belt .....                                | 17        |
| Buckets .....                                    | 19        |
| Centring of bucket belt .....                    | 20        |
| Belt alignment switch .....                      | 21        |
| Adjusting the splash guard .....                 | 22        |
| Elevator hood .....                              | 22        |
| Speed monitor .....                              | 23        |
| Explosion relief panels .....                    | 23        |
| Inlet .....                                      | 23        |
| Water seal .....                                 | 23        |

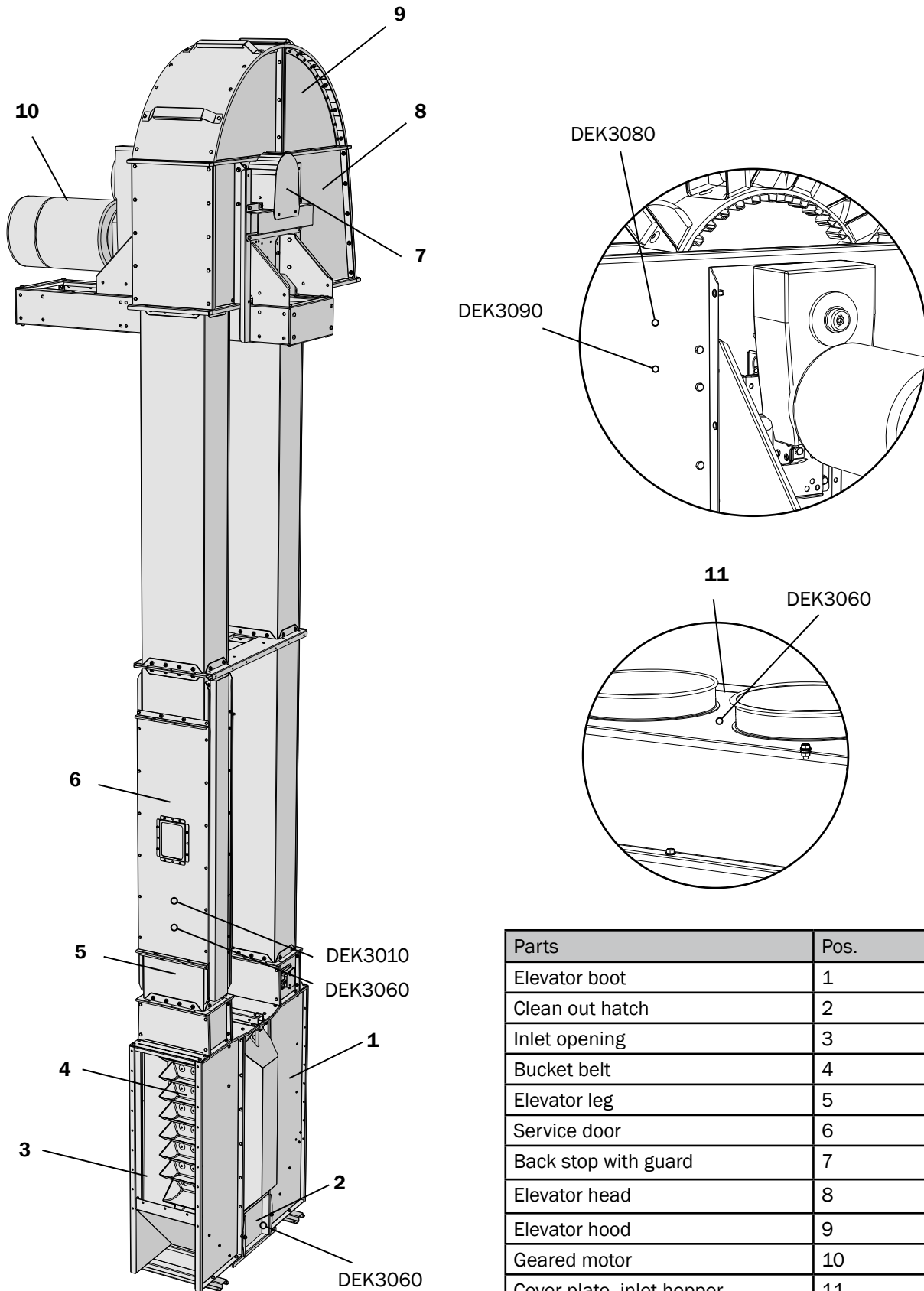

| Parts                     | Pos.   |
|---------------------------|--------|
| Elevator boot             | 1      |
| Clean out hatch           | 2      |
| Inlet opening             | 3      |
| Bucket belt               | 4      |
| Elevator leg              | 5      |
| Service door              | 6      |
| Back stop with guard      | 7      |
| Elevator head             | 8      |
| Elevator hood             | 9      |
| Geared motor              | 10     |
| Cover plate, inlet hopper | 11     |
| Safety decals             | DEKXXX |

The owner of the transport equipment is responsible for these assembly instructions always being available to the fitters, electricians, maintenance technicians and engineering technicians concerned.

Incorrect assembly and/or operation may lead to personal injury or damage to the conveyor equipment and/or other equipment. It can also cause malfunctions or a reduction in capacity.

Read the assembly instructions carefully before assembly, electrical connection, maintenance or operation commences. If any part of these instructions should be difficult to comprehend, please get in touch with your reseller for assistance.

The safety information is presented and interpreted as follows:

**⚠ WARNING!**

Disregarding instructions given in warnings can cause serious personal injury or death.

**⚠ IMPORTANT!**

Ignoring the instructions given in important texts may cause damage to the conveyor equipment and/or other equipment. It can also cause malfunctions or a reduction in capacity.

NB! indicates that the text contains information that will simplify the assembly process.

## General

**⚠ WARNING!**

- Ensure that everyone responsible for assembly, electrical connection, maintenance and operation of the conveyor equipment has read and understood the instructions and safety information.
- Use protective gloves, helmet, steel-toed boots, ear defenders, protective goggles and high-vis vest when carrying out assembly, electrical connection, maintenance and operation of conveyor equipment.



 **WARNING!**

- Stop the machinery and turn off electric power before attempting any type of assembly, electrical connection or maintenance work.
- Do not start the machinery without the elevator hood and all hatches, covers, lids and guards fitted in such a way they can only be opened with tools.
- Connections to, from and between machinery must be permanently mounted and fully enclosed. If the design of the installation does not allow this at an outlet, finish off with a 1 m pipe.

 **IMPORTANT!**

- If the machine is being assembled outdoors, the motors and transmissions must be fitted with a weather cover.
- If a short circuit should occur, ensure that the electrical equipment is in working order before continuing operation.
- Ensure that the electrical equipment is kept free from dirt, dust, moisture and electrostatic charge.

## Electrical connection

Incorrect electrical connection may lead to personal injury or damage to the conveyor equipment and/or other equipment. It can also cause malfunctions or a reduction in capacity.

 **WARNING!**

- All electrical equipment is to be connected by a qualified electrician. See separate connecting directions for electronics.
- The power switch must be permanently mounted and located to allow easy access when carrying out maintenance work.
- Ensure the speed monitor is engaged during operation.

 **IMPORTANT!**

- Ensure the motor protection is set to the correct ampere setting for the motor.
- Read the "Back stop" section in the elevator's assembly instructions before test starting the motor for the first time.
- Ensure all breakers for the belt alignment switch are engaged during operation.
- Ensure all switches for the explosion relief panels (optional accessory) are engaged during operation.

## Maintenance

Inadequate maintenance may lead to personal injury or damage to the conveyor equipment and/or other equipment. It can also cause malfunctions or a reduction in capacity.

 **WARNING!**

Read the separate maintenance instructions before taking the machine into service.



## Safety decals

### **WARNING!**

The machine is supplied with safety decals on delivery. They must not be removed or defaced. If a safety decal becomes damaged, you can order a new one free of charge from Skandia Elevator AB. Specify the part number of the decal. See the section below and the previous chapter Machine Overview.





#### There are safety decals for:





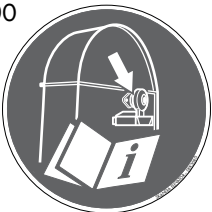

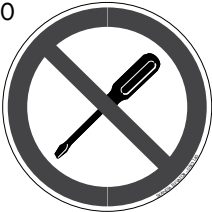
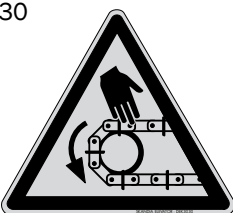

- Mandatory (white symbol on round blue background).
- Forbidden (black strike-through symbol on round white background with red surround).
- Warning (black symbol on triangular yellow background with black surround).

### **WARNING!**

The mandatory instruction, forbiddance or warning given on all safety decals must be considered or serious injury or death may follow.

Skandia Elevator machines have the following safety decals:

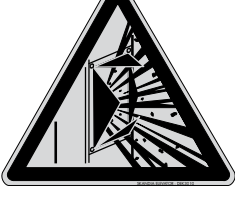
| <b>Part number/Safety decal</b><br>Refer to the "Machine Overview" chapter for placement.      | <b>Written definition</b>   |
|--|---|
| DEK3090<br>  | Read the "Back stop" section in the elevator's assembly instructions before test starting the motor for the first time. |
| DEK3100<br> | Do not place the valve with the motor side face down.   |
| DEK3140<br> | Changing settings and equipment is prohibited.  |
| DEK3030<br> | Warning for conveyor chain!   |
| DEK3060<br> | Warning for bucket belt!  |

|  |   |
|--|---|
| <p>DEK3040</p>    | <p>Warning for chain drive!</p>   |
| <p>DEK3050</p>    | <p>Warning for belt drive!</p>  |
| <p>DEK3070</p>    | <p>Warning for rotating conveyor drive shaft!</p>   |
| <p>DEK3080</p>   | <p>Warning for rotating elevator drive shaft!</p>   |
| <p>DEK3110</p>  | <p>Warning for moving machinery!</p>  |
| <p>DEK3120</p>  | <p>Warning for moving machinery!</p>  |
| <p>DEK3010</p>  | <p>Warning for dust explosion!</p>  |
| <p>DEK3130</p>  | <p>Warning, a maximum of 2 people = 200 kg/440 lbs may be on the platform and ladders simultaneously!</p> |

**⚠ IMPORTANT!**

- Ensure that an elevator with standard plate thickness used in the elevator legs is not built higher than permitted. Refer to the "Technical specifications" section in the separate "Maintenance instructions".
- Sections can be assembled together to a maximum of 8 metres in length and then lifted into place. The weight must be distributed over several lifting points.
- The elevator is to be braced every 4 metres to a leg joint. The top brace can be to a support frame. Bracing must be carried out so that it can withstand the expected load.
- Ensure there is no risk of the elevator boot standing in water. Lift/raise it if necessary.

NB! Place the elevator boot so that the clean-out hatch (A) is easily accessible and planned connections can be made.

When feeding from one side only, remove rib plate (B) and fit cover plate (C) over the unused inlet.

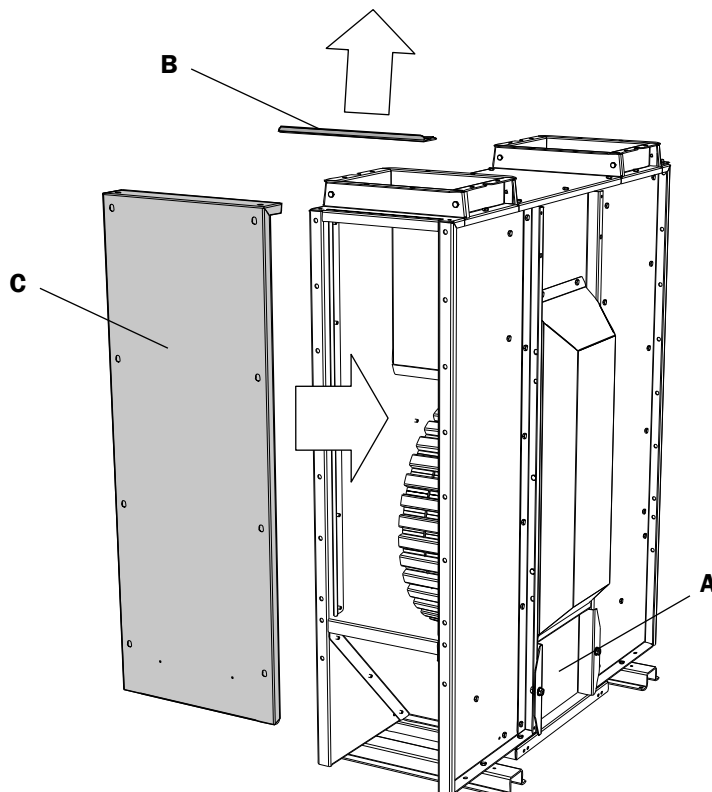

**⚠ IMPORTANT!**

Assemble the elevator level within specified tolerances (X and Y are vertical references and Z is a parallel reference).

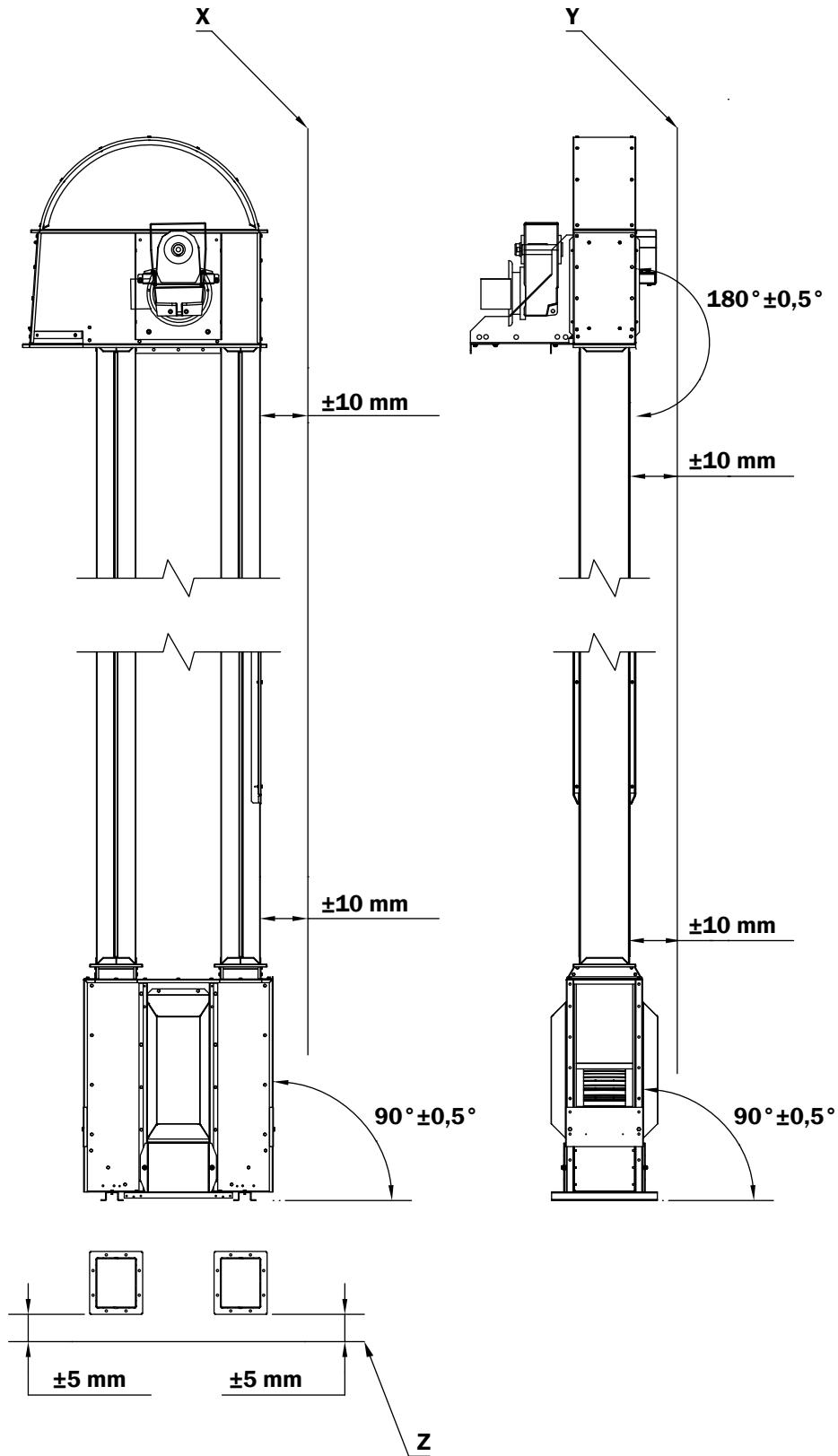

**⚠ IMPORTANT!**

- Mealy, light material and slow running material must always be fed on the descending leg side. Use only recommended inlet, outlet and connecting components.
- Ensure the ducting is dimensioned sufficiently and that its angle of inclination is at least 45°.

## Location of inlet

**⚠ WARNING!**

Unused inlets are to be sealed.

**⚠ IMPORTANT!**

- Assemble the inlet at the height shown in the illustration.
- Always use the cover on the inlet hopper (A).

A. Inlet hopper

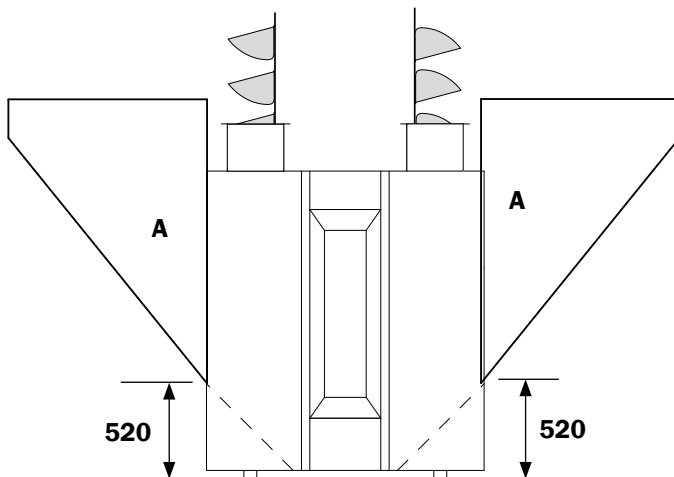

## Connecting another machine to the elevator

A conveyor or elevator can be connected to an elevator via an inlet hopper (A, B).

## Connecting the elevator to the conveyor

Connect the elevator to the conveyor according to the assembly instructions for the respective conveyor.

## Elevator legs

### **IMPORTANT!**

The elevator is to be braced every 4 metres to a leg joint. The top brace can be to a support frame. Bracing must be carried out so that it can withstand the expected load.

Fit the legs with a leg spacer plate in each join.

NB! The legs have female and male joining pieces that are to be fitted together.

NB! Fit the leg with the service door on the ascending leg side at ground level.

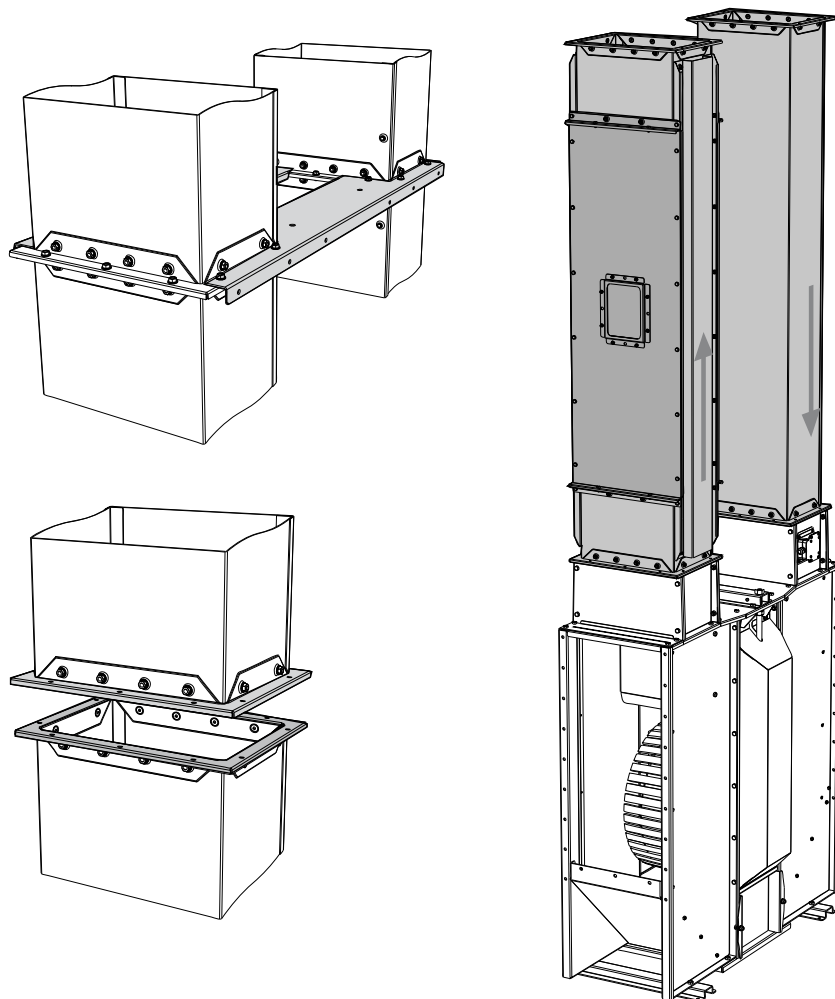

**⚠ IMPORTANT!**

If the legs are of the type assembled with bolt unions, the longitudinal joints (B) on the legs must be facing each other.

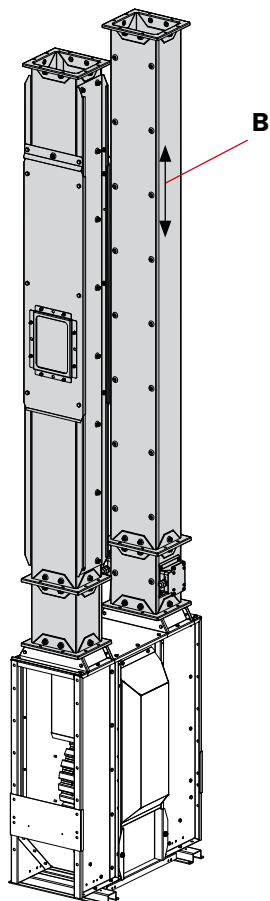

## Elevator head

Fit the elevator head.

**⚠ IMPORTANT!**

Relieve the weight of the elevator head with braces to the ground and/or a nearby stable construction. Brace the geared motor support frame. Never use the geared motor to brace on.

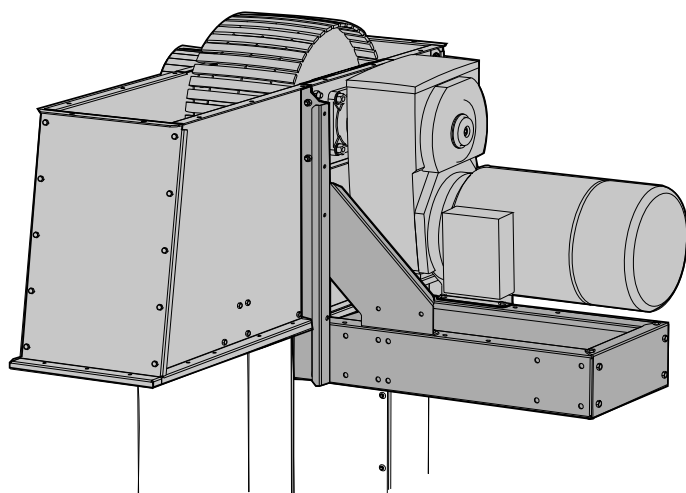

## Back stop

The back stop prevents the bucket belt reversing if the elevator stops during operation. It is mounted on the drive shaft protected behind a touch guard.

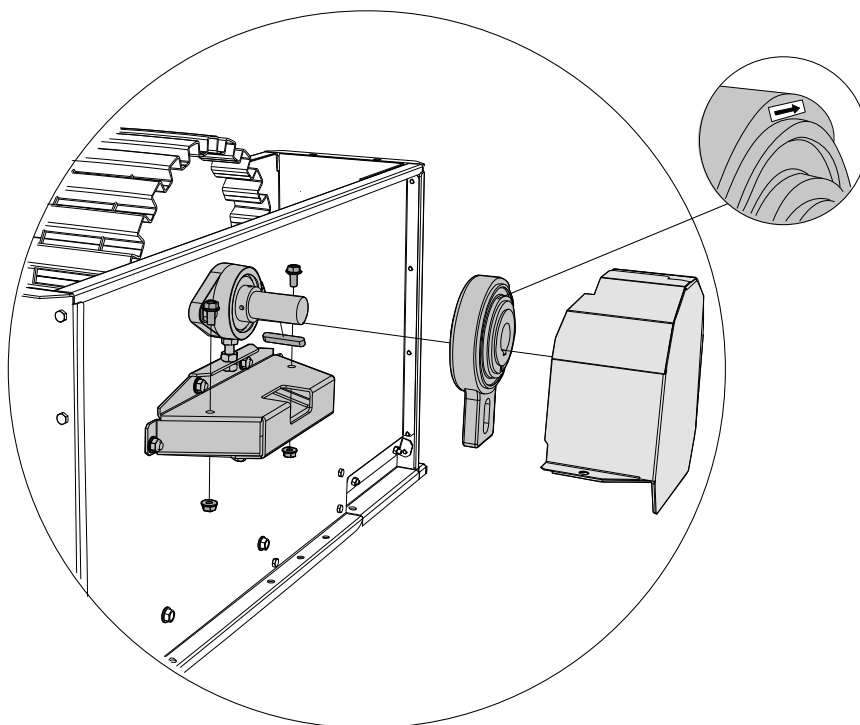

### **⚠ WARNING!**

Ensure the back stop and its touch guard are fitted at all times except during the start-up trial of the elevator. Detail (A) on the back stop must be assembled so that the side marked with the arrow is turned outward and the arrow pointing in the direction of travel.

### **⚠ IMPORTANT!**

- Remove the back stop from the drive shaft before the elevator is test started for the first time. Ensure that the bucket belt runs in the correct direction before refitting the back stop. The damage that can be caused to the back stop/geared motor by an incorrectly connected geared motor is not covered by the warranty.
- In the event of stoppage in operation, troubleshoot as described in the maintenance instructions and ensure the elevator boot is free of material before restarting.

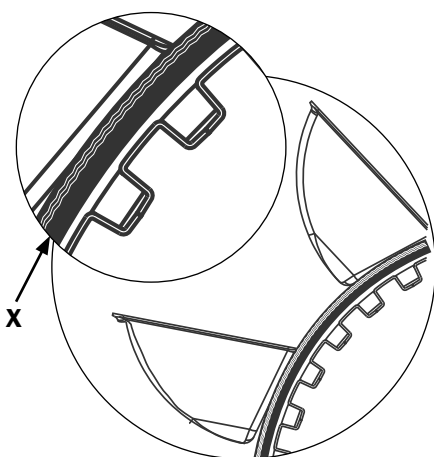

## Bucket belt

### **⚠ WARNING!**

The bucket belt is always to be inserted/removed/tightened in situ using a vertical force or there is a risk of uneven loading and collapse of the legs.

### **⚠ IMPORTANT!**

Ensure that the bucket belt is fitted with the thickest rubber coating (X) (3 mm) turned toward the slatted pulleys.



Check that the bucket belt is running on the slatted pulleys. If it gets twisted it must be adjusted.

**⚠ IMPORTANT!**

If the adjustable slatted pulley in the elevator boot is to achieve maximum capacity, it must be in as low a position as possible after the bucket belt has been assembled and restretched.

1. Remove the service doors on both sides of the elevator leg.
2. Retighten the bucket belt as described in "Bucket belt"
3. Pull the bucket belt in place over the slatted pulleys so that the joints position themselves in the service opening.
4. Fit the descending belt end between the sleeve profile (A) and the backing profile (B) with nut and bolt. NB! If the hole pattern does not align, only the outer holes need to be used.
5. Lubricate the threaded rods (C) and lower them into the sleeve profile (A).
6. Screw the threaded rods through the nut profile (D) so that they stick out slightly below.
7. Pull up the ascending belt end as much as possible by hand and fit it to the nut profile (D) with backing profile (E).

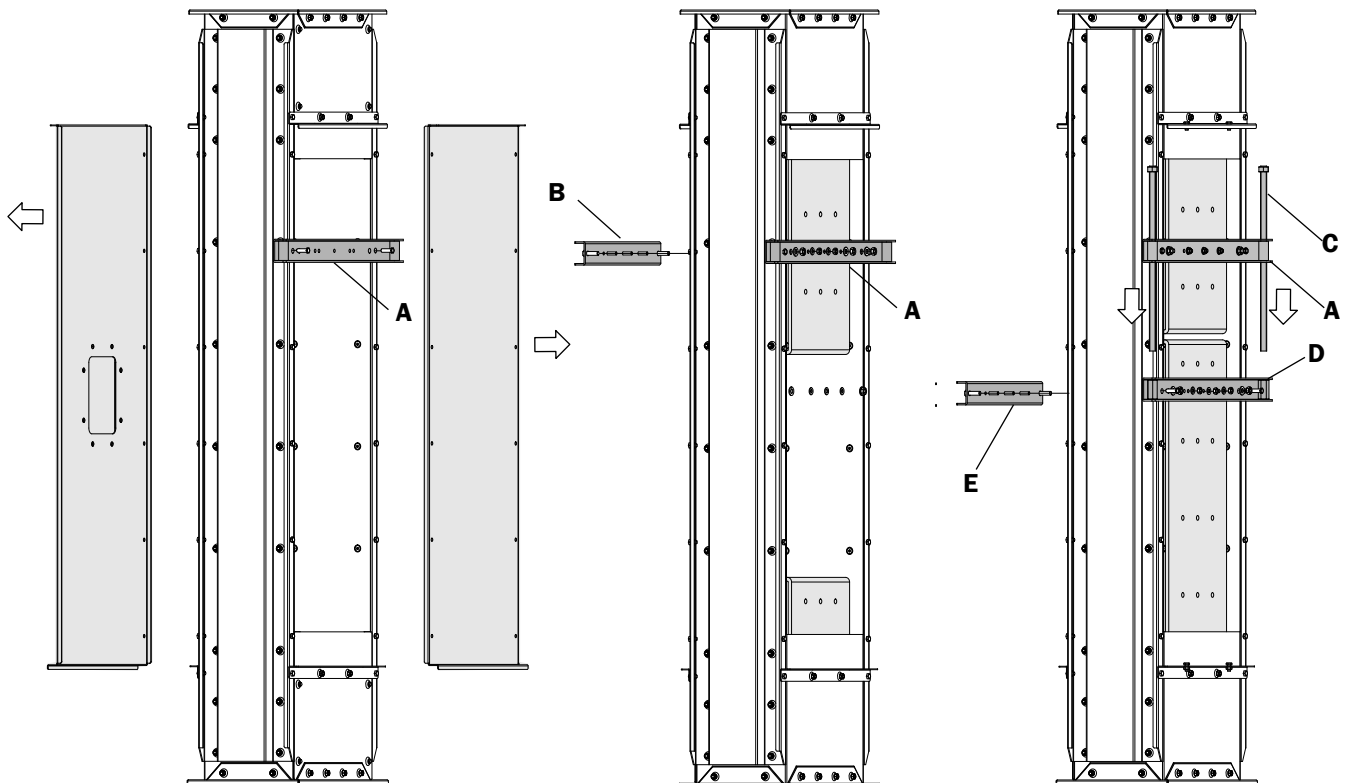

8. Tension the bucket belt by screwing the threaded rods further into the nut profile.
9. Position the splice bars (F) over the join, make holes in the bucket belt and assemble together.
10. Cut the belt ends 10 mm outside the splice bars and remove the belt tensioner profiles.
11. Mount the buckets as described below under "Buckets".
12. Once the buckets have been mounted, tension the bucket belt further with the tensioning bolts (G) in the elevator boot. Recommended torque for belt tensioning is specified in the section "Technical specifications" in the separate maintenance instructions.

**⚠ IMPORTANT!**

Bucket belt tension must be checked and adjusted shortly after the elevator has been taken into service. Follow the description in the separate maintenance instructions.

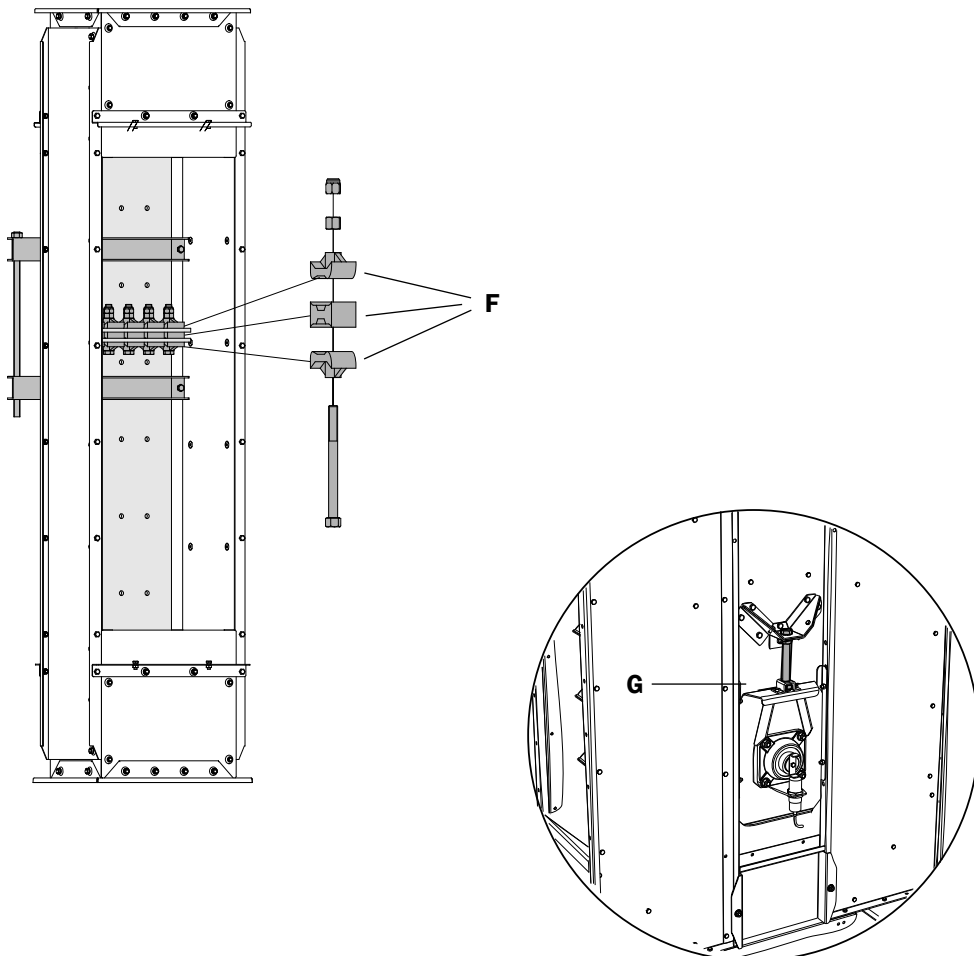

## Buckets

### **WARNING!**

The buckets can have sharp edges.

1.

### **WARNING!**

The buckets are to be mounted so their weight is distributed evenly over the bucket belt during assembly.

Mount 10 buckets, one directly after the other, and then leave a space corresponding to 11 buckets. Repeat this around the belt.

Mount half the number of buckets on the next turn. Repeat turn after turn until all the buckets are mounted.

### **IMPORTANT!**

Fit the washers as illustrated and tighten the nuts hard enough so that the screw heads align exactly with the surface of the bucket belt.

NB! The bucket belt can only be drawn upwards as the back stop prevents it from going down.

2.

Retighten the bucket belt as described in "Bucket belt" (12).

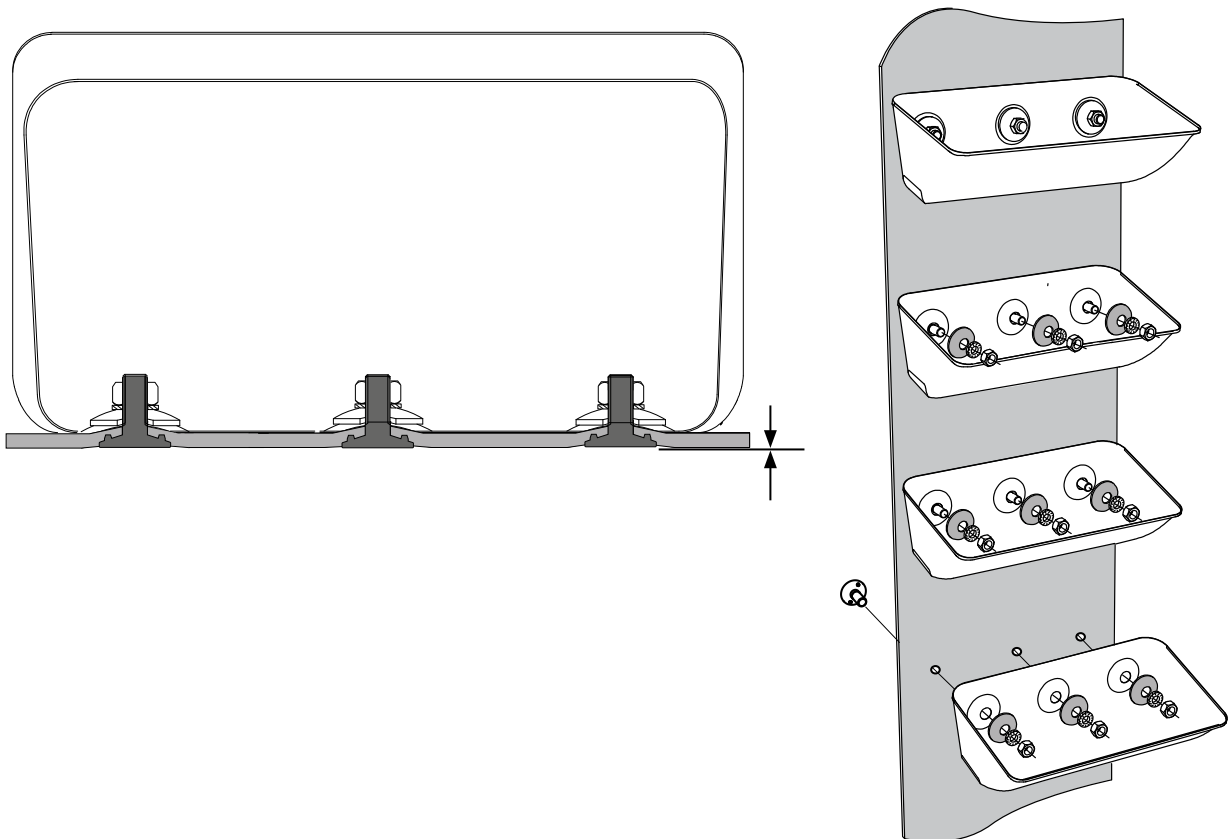

## Centring of bucket belt

### **IMPORTANT!**

Ensure the bucket belt is centred on the slatted pulleys.

Check that the bucket belt is running on the slatted pulleys. If it gets twisted it must be adjusted.

### **Example:**

If the bucket belt is running to the right on the slatted pulley in the elevator boot. Raise the slatted pulley (D) on the left-hand side plate by reducing the tension of the tensioning bolt (E) until the bucket belt is running centred.

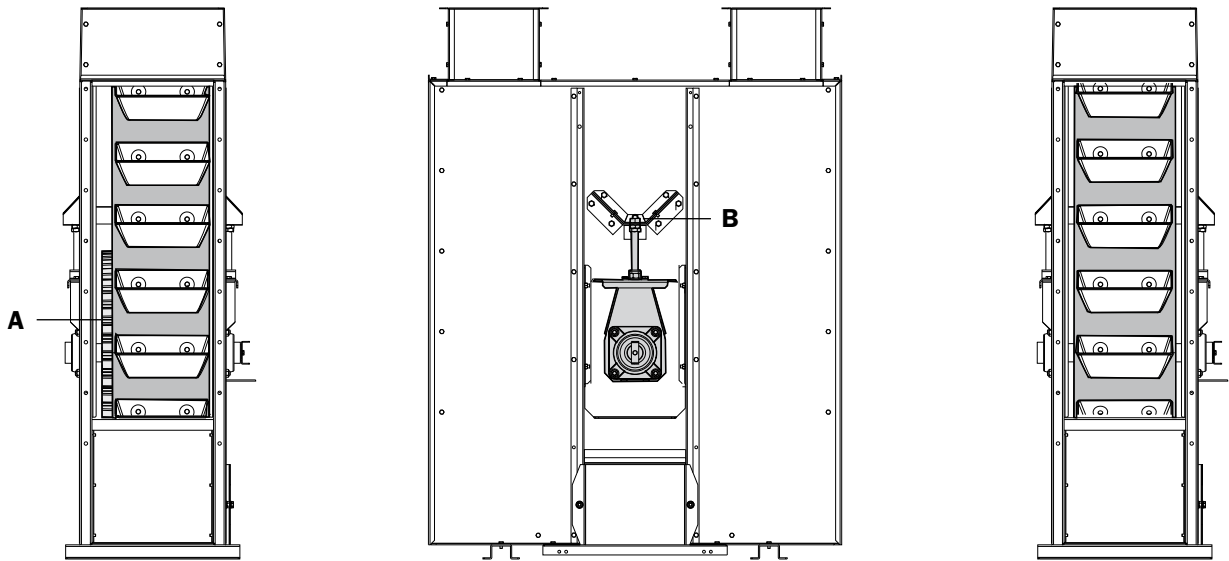

## Belt alignment switch

The belt alignment switch is built into the elevator boot and it stops the elevator if the bucket belt starts to run untrue on the slatted pulleys.

**⚠ WARNING!**

All electrical equipment is to be connected by a qualified electrician.  
See separate connecting directions for electronics.

**⚠ IMPORTANT!**

The belt must be able to move 10-15 mm to both sides without the belt alignment switch cutting the power.

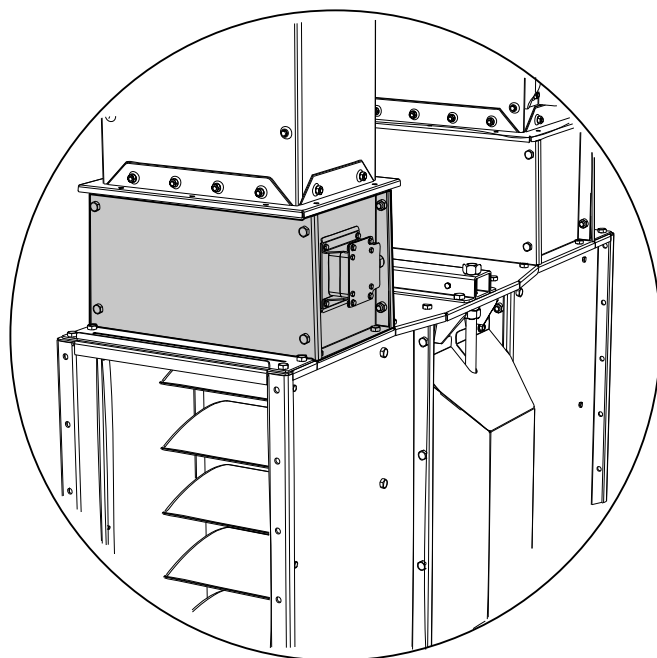

## Adjusting the splash guard

Set the distance of the splash guard (A) as illustrated.

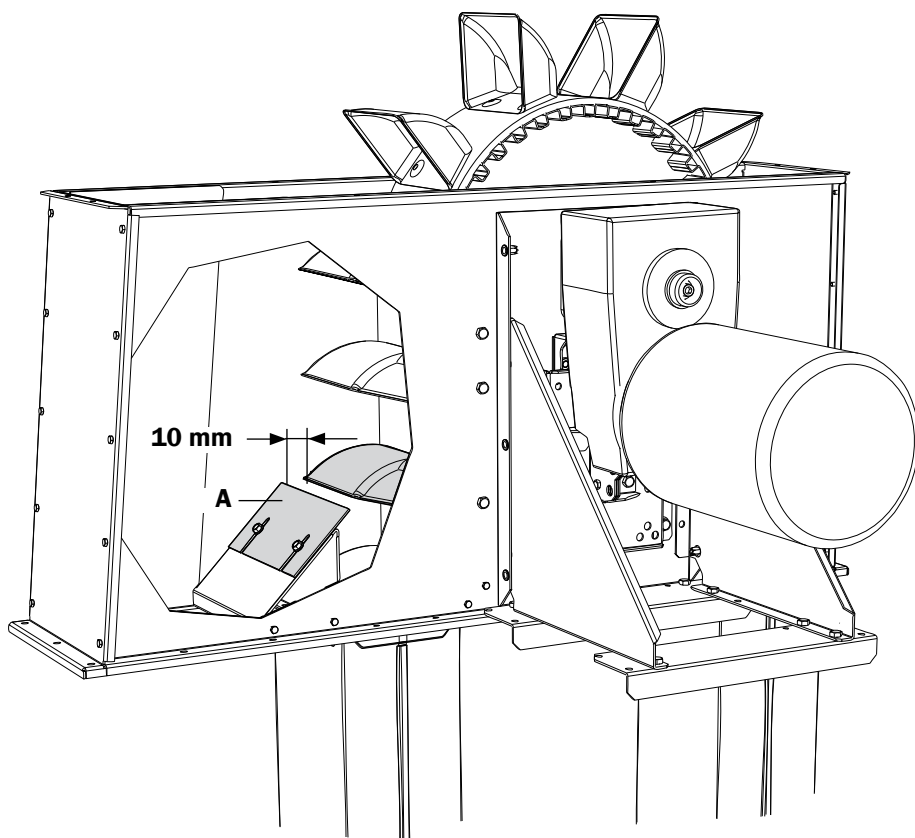

## Elevator hood

Fit the elevator hood.

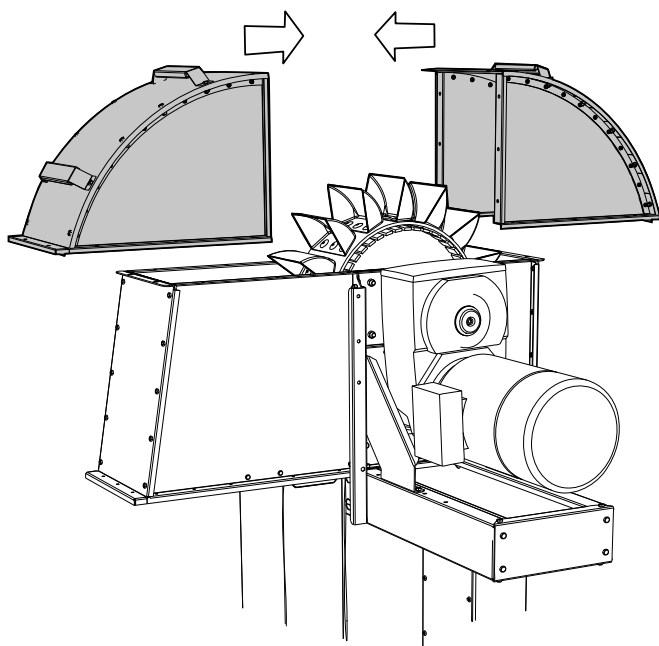

### **⚠ WARNING!**

The rotating drive shaft is partially exposed between the gearbox motor and the drive if the weather cover is not used.

## Speed monitor

The speed monitor stops the elevator if the bucket belt slips.

### **WARNING!**

- Ensure the speed monitor is engaged during operation.
- All electrical equipment is to be connected by a qualified electrician. See separate connecting directions for electronics.

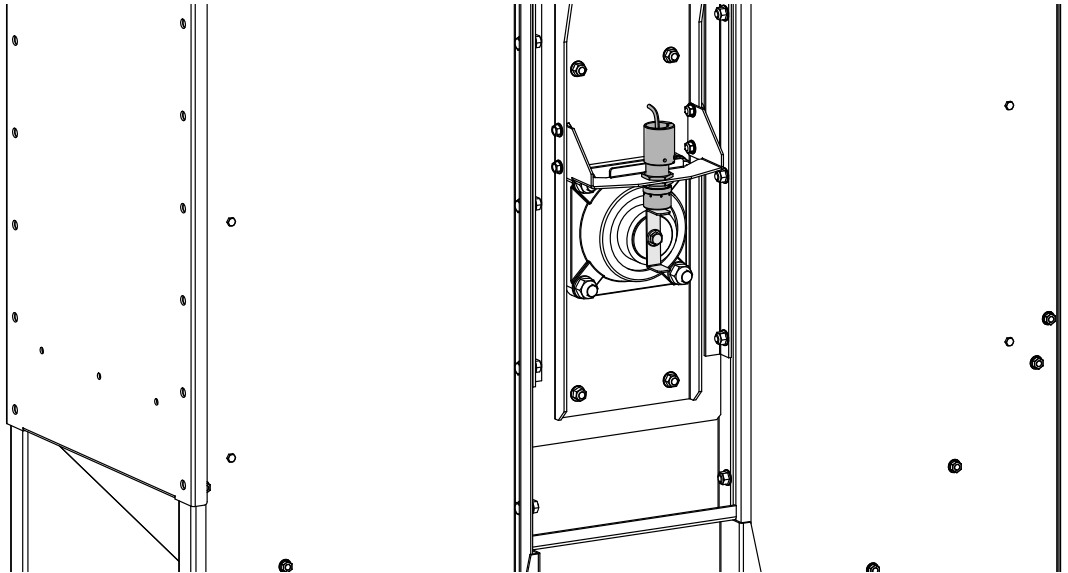

## Explosion relief panels

### **WARNING! & IMPORTANT!**

If the elevator is equipped with explosion relief panels, assemble them in the first pair of legs and then at a minimum of 6-meter intervals. Use only explosion relief panels supplied by Skandia Elevator.

### **WARNING!**

- Never stand in front of an explosion relief panel while the elevator is in operation.
- All electrical equipment is to be connected by a qualified electrician. See separate connecting directions for electronics.

## Inlet

Assemble the inlet at the height specified in the "Connection of the machine" section.

## Water seal

### **IMPORTANT!**

When assembling outdoors, seal all the bolts, flanges and folds with silicone.



**SKANDIA ELEVATOR AB**

KEDUMSVÄGEN 14, ARENTORP  
S-534 94 VARA, SWEDEN

PHONE +46 (0)512 79 70 00  
FAX +46 (0)512 134 00

INFO@SKANDIA-ELEVATOR.SE  
WWW.SKANDIA-ELEVATOR.SE